

TSTP2

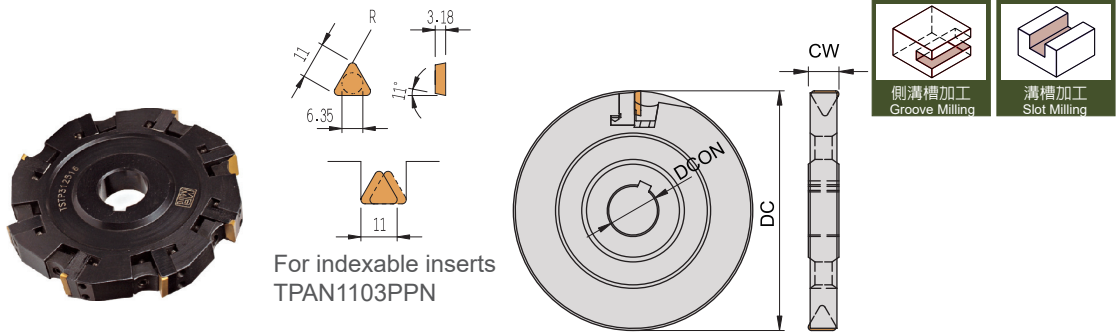

▼Recommended Inserts 刀片建議品牌: KENNAMETAL & WIDIA

Order No.	Insert	Dimensions(mm)					Locator		Locator Screw	Clamp	Clamp Screw	Wrench
		刀徑 DC	切寬 CW	孔徑 DCON		刃數 I No.	(R)	(L)				
TSTP208012	TP..1103	80	12	27	1"	6	TSL60-12	TSL60-13	CS9-3003 CS9-3006	CP50-6	CS7-6016	LW030 LW015
TSTP210012		100	12	27	1"	8						
TSTP212512		125	12	32	1-1/4"	10						
TSTP216012		160	12	32	1-1/4"	12						

TSTP3

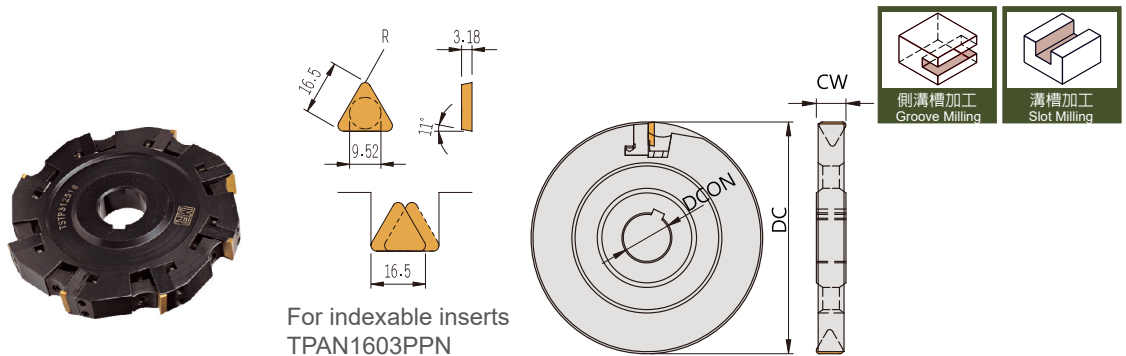

▼Recommended Inserts 刀片建議品牌: KENNAMETAL & WIDIA

Order No.	Insert	Dimensions(mm)					Locator		Locator Screw	Clamp	Clamp Screw	Wrench
		刀徑 DC	切寬 CW	孔徑 DCON		刃數 I No.	(R)	(L)				
TSTP310016	TP..1603	100	16	27	1"	6	TSL60-14	TSL60-15	CS9-4003 CS9-4012	CP50-9	CS7-6016	LW030 LW020
TSTP310018		100	18	27	1"	6						
TSTP312516		125	16	32	1-1/4"	8						
TSTP312518		125	18	32	1-1/4"	8						
TSTP312520		125	20	32	1-1/4"	8						
TSTP316016		160	16	32	1-1/4"	10						
TSTP316018		160	18	32	1-1/4"	10						
TSTP316020		160	20	32	1-1/4"	10						
TSTP320018		200	18	40	1-1/2"	12						
TSTP320020		200	20	40	1-1/2"	12						
TSTP325018		250	18	50	2"	16						
TSTP325020		250	20	50	2"	16						