

## VXF

### 高進給端銑刀

High feed end mills

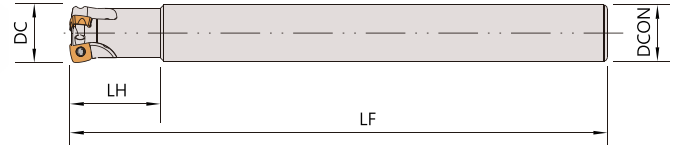
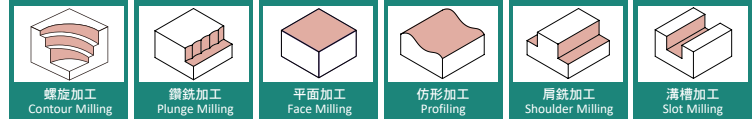

with coolant 含油孔

Recommended Inserts 建議刀片品牌: WIDIA

Order No.	Insert	Dimensions(mm)					Screw	Wrench
		刀徑	長度	頭長	柄徑	刃數		
Right / Left	 XPPT0703	DC	LF	LH	DCON	I No.	 CS30053	 DT-8
VXF017Z02A16XP07L180		17	180	25	16	2		
VXF021Z03A20XP07L190		21	190	32	20	3		

## VXF-H

### 鎖牙式端銑刀

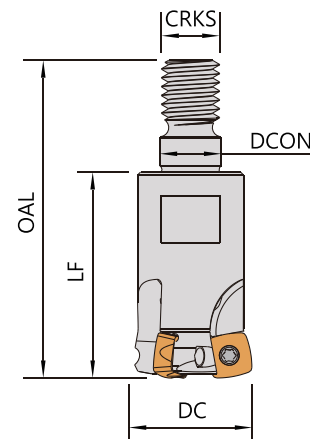
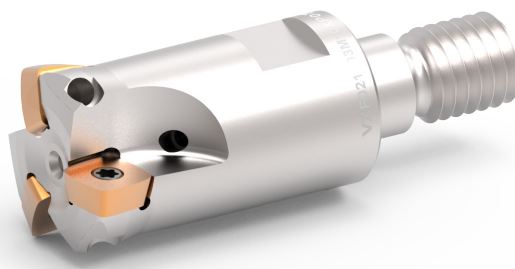
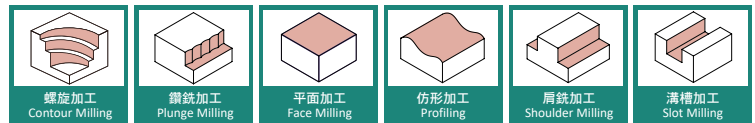

with coolant 含油孔

Recommended Inserts 建議刀片品牌: WIDIA

Order No.	Insert	Dimensions(mm)						Screw	Wrench
		刀徑	柄徑	總長	長度	螺紋	刃數		
Right / Left	 XPPT0703	DC	DCON	OAL	LF	CRKS	I No.	 CS30053	 DT-8
VXF017Z02M08XP07-H		17	8.5	43	25	4	2		
VXF021Z03M10XP07-H		21	10.5	54	35	5	3		