

EXN
高進給銑刀

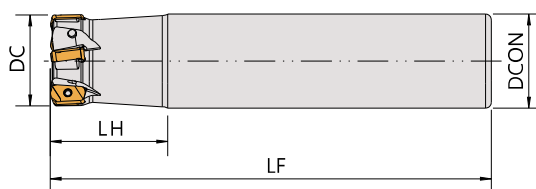
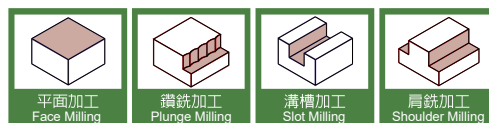

公制型

High feed end mills
Double sided insert with 4 cutting edges

▼Recommended Inserts 建議刀片品牌: TUNGALOY / ACC

Order No.	Insert	Dimensions(mm)					Screw	Wrench
		刀徑 DC	柄徑 DCON	頭長 LH	長度 LF	刃數 I No.		
Right / Left								
短頸型 (Short-neck Type)								
EXN03R1602S16	LNMU0303	16	16	20	100	2	CS2508PS	FT-8P
EXN03R1702S16		17	16	20	100	2		
EXN03R2003S20		20	20	25	130	3		
EXN03R2103S20		21	20	25	130	3		
EXN03R2504S25		25	25	30	140	4		
EXN03R2604S25		26	25	30	140	4		
EXN03R3205S32		32	32	40	150	5		
EXN03R3305S32		33	32	40	150	5		
EXN03R3505S32		35	32	40	150	5		
長柄型 (Long Shank)								
EXN03R1602S16-L150B50	LNMU0303	16	16	50	150	2	CS2508PS	FT-8P
EXN03R2003S20-L160B80		20	20	80	160	3		
EXN03R2504S25-L180B100		25	25	100	180	4		
長頸型 (Long-neck Type)								
EXN03R1602S16-B30	LNMU0303	16	16	30	100	2	CS2508PS	FT-8P
EXN03R1702S16-B30		17	16	30	100	2		
EXN03R2003S20-B50		20	20	50	130	3		
EXN03R2103S20-B50		21	20	50	130	3		
EXN03R2504S25-B60		25	25	60	140	4		
EXN03R2604S25-B60		26	25	60	140	4		
EXN03R3205S32-B70		32	32	70	150	5		
EXN03R3305S32-B70		33	32	70	150	5		
EXN03R3505S32-B70		35	32	70	150	5		

EXN
高進給銑刀

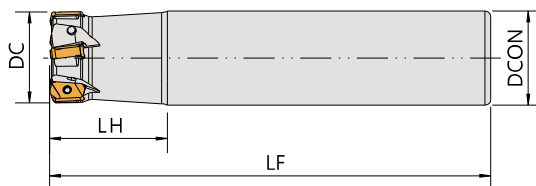
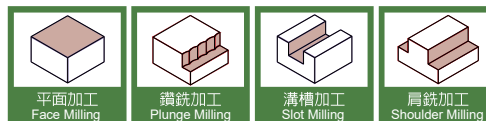

High feed end mills
Double sided insert with 4 cutting edges

英制型

▼Recommended Inserts 建議刀片品牌: TUNGALOY / ACC

Order No.	Insert	Dimensions					Screw	Wrench
		刀徑	柄徑	頭長	長度	刃數		
Right / Left		DC	DCON	LH	LF	I No.		
英制 (inch)								
EXN03R062U0062-02	LNMU0303	.6250	.625	1.250	4.000	2	CS2508PS	FT-8P
EXN03R068U0062-02		.6880	.625	1.250	4.000	2		
EXN03R075U0075-03		.7500	.750	2.000	5.000	3		
EXN03R087U0075-03		.8750	.750	2.000	5.000	3		
EXN03R100U0100-04		1.0000	1.000	2.500	5.500	4		
EXN03R112U0100-04		1.1250	1.000	2.500	5.500	4		
EXN03R125U0125-06		1.2500	1.250	3.000	6.000	6		

TXN
殼形銑刀

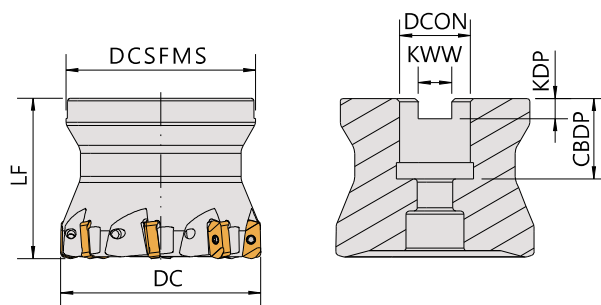
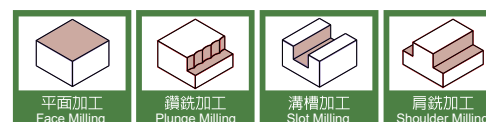

High feed shell end mills
Double side insert with 4 cutting edges

▼Recommended Inserts 建議刀片品牌: TUNGALOY / ACC

Order No.	Insert	Dimensions(mm)				Screw	Wrench	
		刀徑	長度	孔徑				刃數
Right / Left		DC	LF	DCON	DCON(inch)	I No.		
TXN03R4006	LNMU0303	40	40	16	-	6	CS2508PS	FT-8P
TXN03R5007		50	50	22	-	7		
TXN03R6308		63	50	22	1"	8		



Modular End Mill

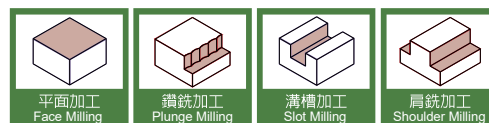

High feed shell end mills
Double side insert with 4 cutting edges

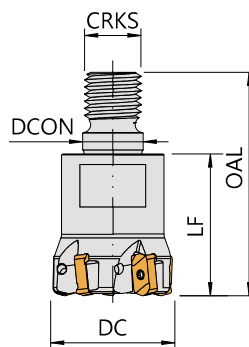

▼ Recommended Inserts 建議刀片品牌: TUNGALOY / ACC

Order No.	Insert	Dimensions(mm)						Screw	Wrench
		刀徑 DC	柄徑 DCON	總長 OAL	長度 LF	螺紋 CRKS	刃數 I No.		
HXN03R1602	LNMU0303	16	8.5	42	25	M8	2	CS2508PS	FT-8P
HXN03R1702		17	8.5	42	25		2		
HXN03R2003		20	10.5	49	30	M10	3		
HXN03R2103		21	10.5	49	30		3		
HXN03R2504		25	12.5	57	35	M12	4		
HXN03R2604		26	12.5	57	35		4		
HXN03R3205		32	17	63	40	M16	5		
HXN03R3305		33	17	63	40		5		
HXN03R3505		35	17	63	40		5		

▼ Inserts 刀片:

●: Stock / ◎: 1st Choice, ○: 2nd Choice, X: Not Recommend

Tolerance Class 精度	M級	P 鋼 Carbon Steels		◎	◎	◎	Dimensions(mm) 尺寸				
		M 不鏽鋼 Stainless Steels		◎							
		K 鑄鐵 Cast Iron	◎								
		S 高溫合金 Superalloys	○								
		H 高硬度 Hard Materials	○								
Specification 規格			Grade 材質				Dimensions(mm) 尺寸				
			AH725	AH3035	AH130	NA253A	IC	t	B	r	Max.ap
		LNMU0303ZER-MJ	●	●	●	●	6.0	4.3	6.0	1.2	1
		LNMU0303ZER-ML	●	●	●		6.0	4.3	6.0	1.2	1