

# Grooving Tools 槽刀

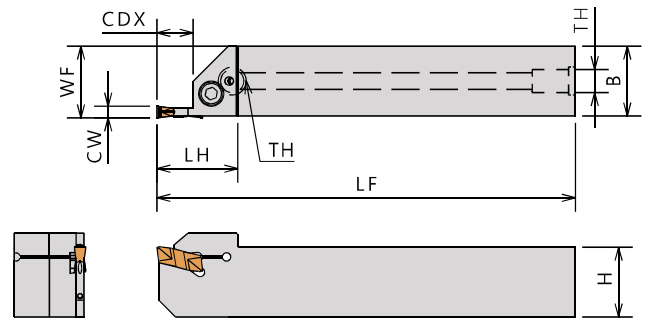
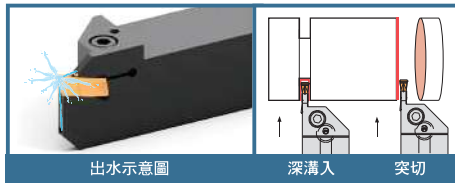

▼Recommended Inserts 建議刀片品牌：ISCAR

Order No.	Insert	Dimensions(mm)									Insert Screw	Coolant plug	Adapter	Wrench
		柄高	柄寬	總長	寬度	頭長	切寬	切深	下巴厚	牙孔				
Right / Left		H	B	LF	WF	LH	CW	CDX	HBH	Th				
AGHSR1212JX03-10R	GIP 3.00-020	12	12	120	12.6	27	3	10	2	5/16"	CSH0512	CS9NN CS9-3003	AA-NP	LW040
AGHSR1616JX03-10R		16	16	120	16.6	26	3	10	2	1/8"				
AGHSR2020K03-10		20	20	125	20.6	27	3	10	-	1/8"				
AGHSR2525M03-12JS		25	25	150	25.6	29	3	12	-	1/8"	CSH0516	CS9NQ CS9-3003		
AGHSR2525M04-12JSWP		GIP 4.00	25	25	150	25.6	29	4	12	-			1/8"	

WP : Multiple coolant direction 上下雙出水