

## 平面銑刀 // 編碼規則

## Identificaton System of Face Milling Cutters

F45HN09 // SPECIFICATIONS					
1 規格代號	2 刀徑	3 孔型	4 刃數	5 加工方向	6 特殊註記
<b>F45HN09</b>	<b>D050</b>	<b>A</b>	<b>04</b>	<b>R/L</b>	
Item code	Cutting diameter	Hole type	Blades	Direction	Sign

1 F = 平面銑刀 Face mill  
45 = 角度 Angle  
HN09 = 刀片型號 Insert model

2 刀徑代號「DC」Cutting diameter  
尺寸 Size : 50、63、80、100、125...

6 特殊註記代號 Sign : S、H、SH  
S = 墊片型 With shim  
H = 含油孔 With cooling channel  
SH = 墊片型含油孔 With shim and cooling channel

其他規格代號  
LF = 長度 Length  
DCX = 最大刀徑 Cutting diameter maximum  
DCON = 孔徑(公/英制) Connection diameter  
DCSFMS = 夾持接觸面直徑 Contact surface diameter machine side

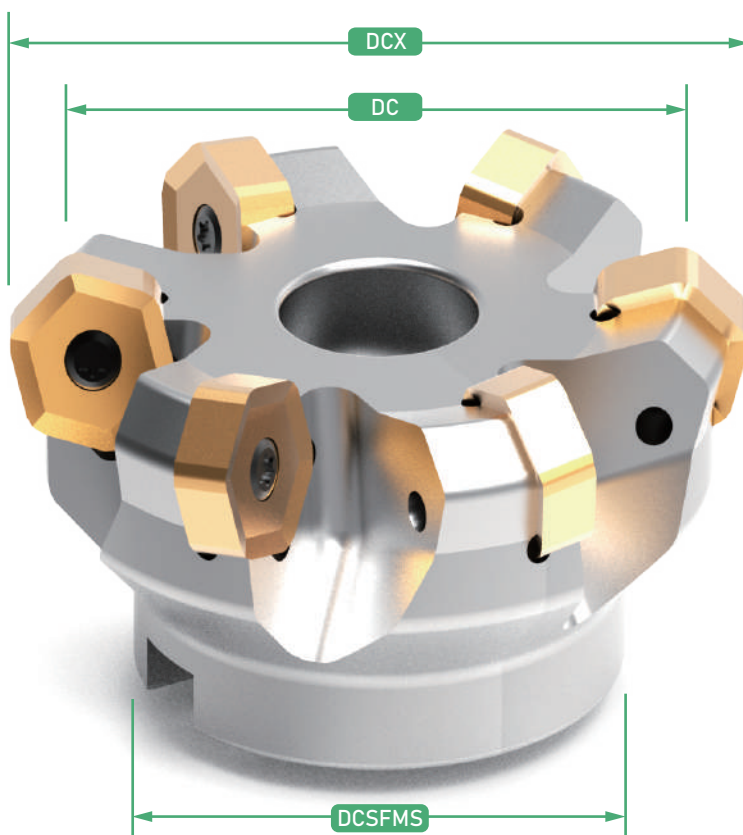

※部分規格若有標示水滴，則代表含油孔

\*Some specifications are marked with water drop which means that it has coolant holes.

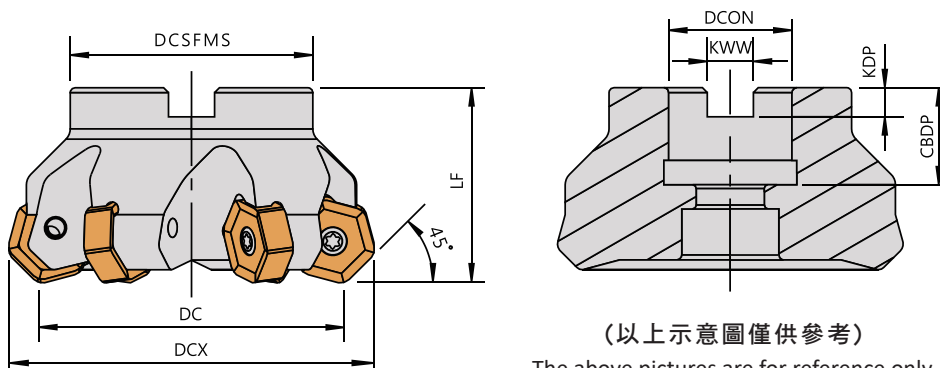

(以上示意圖僅供參考)  
The above pictures are for reference only.