

## MTAN

90°

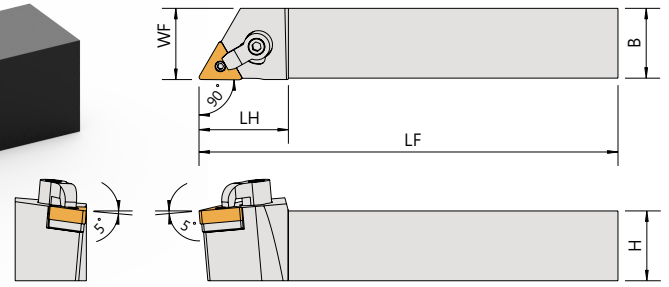
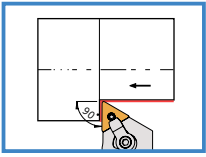

Order No.	Insert	Dimensions(mm)					Parts				Wrench	
		柄高 H	柄寬 B	長度 LF	頭長 LH	工作寬度 WF						
MTANR/L-2020K16	TNMG1604	20	20	125	32	20.5	SMT-322	LCS-513	CP50-22	CS7-6030	LW020	LW030
MTANR/L-2525M16		25	25	150	32	25.5						

## MTENN

60°

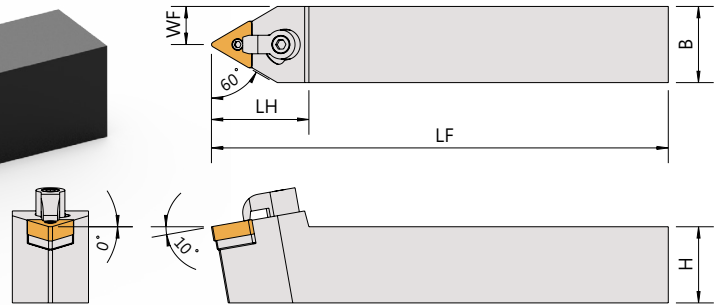
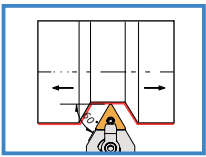

Order No.	Insert	Dimensions(mm)					Parts				Wrench	
		柄高 H	柄寬 B	長度 LF	頭長 LH	工作寬度 WF						
MTENN-1616K16	TNMG1604	16	16	125	33	8	SMT-322	LCS-513	CP50-22	CS7-6030	LW020	LW030
MTENN-2020K16		20	20	125	38	10						
MTENN-2525M16		25	25	150	40	12.5						
MTENN-3225P16		32	25	170	38	12.5						
MTENN-3232P16		32	32	170	43	16						
MTENN-2525M22	TNMG2204	25	25	150	40	12.5	SMT-433	LCS-617	CP50-28	CS7-8030	LW030	LW040
MTENN-3225P22		32	25	170	43	12.5						
MTENN-3232P22		32	32	170	43	16						