

Threading Tools 牙刀

ASER
ASER-N/NA

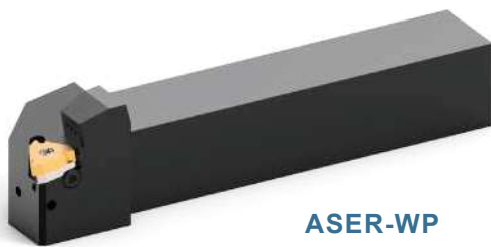

ASER-WP

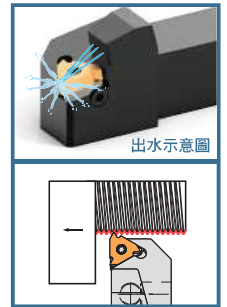
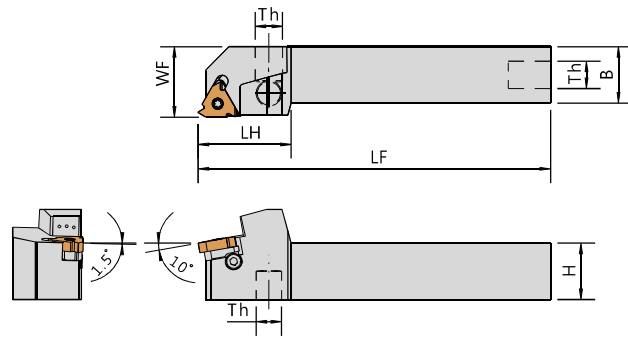
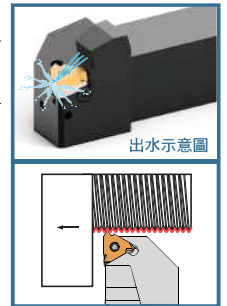
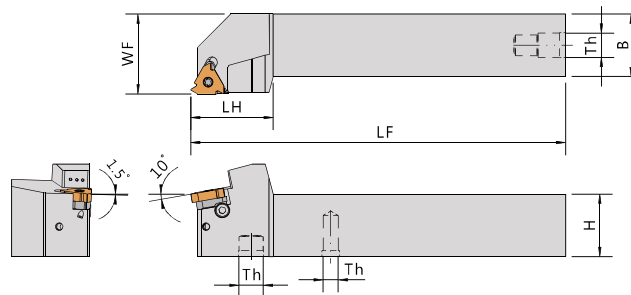

ASER-NA

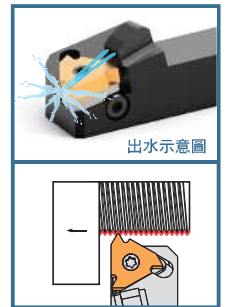
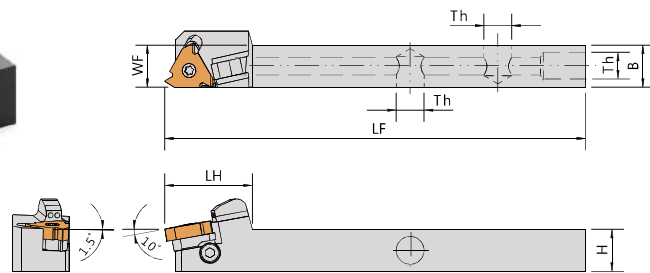

Order No.	Insert	Dimensions(mm)						Shim		Screw	Insert Screw	Coolant plug	Wrench	
		柄高	柄寬	總長	頭長	寬度	牙孔	墊片		螺絲	刀片螺絲	止付螺絲	板手	
Right / Left		H	B	LF	LH	WF	Th	Shim R	Shim L					
ASER-2020K16A	16ER	20	20	125	33	25	1/8"	AE16	AI16	CSH0306	CS35117S	CS9NQ CS9-3003	FT-15	LW025 LW050
ASER-2525M16WP		25	25	150	33	32	1/8"							

WP : Multiple coolant direction 上下雙出水

Order No.	Insert	Dimensions(mm)						Shim		Screw	Insert Screw	Coolant plug	Adapter	Wrench	
		柄高	柄寬	總長	頭長	寬度	牙孔	墊片		螺絲	刀片螺絲	止付螺絲	轉接頭	板手	
Right / Left		H	B	LF	LH	WF	Th	Shim R	Shim L						
ASER-1212JX16NA	16ER	12	12	120	25	12	5/16"	AE16	AI16	CSH0306	CS35117S	CS9NN CS9-4004	AA-NP	FT-15	LW025 LW040
ASER-1616JX16NA		16	16	120	25	12	1/8"					CS9NQ CS9-4004			
ASER-2020K16NA		20	20	125	26	20	1/8"					-			
ASER-2525M16NA		25	25	150	26	25	1/8"					CS9NQ			